

Original design (LilyPad Arduino v1.6) by L. Buechley and N. Seidle  
 Released under the Creative Commons Attribution Share-Alike 3.0 License  
<http://creativecommons.org/licenses/by-sa/3.0>  
 Design by: S. Kobayashi and N. Seidle  
 Modifications by Matthew Ford, Forward Computing and Control Pty. Ltd. ([www.forward.com.au](http://www.forward.com.au))

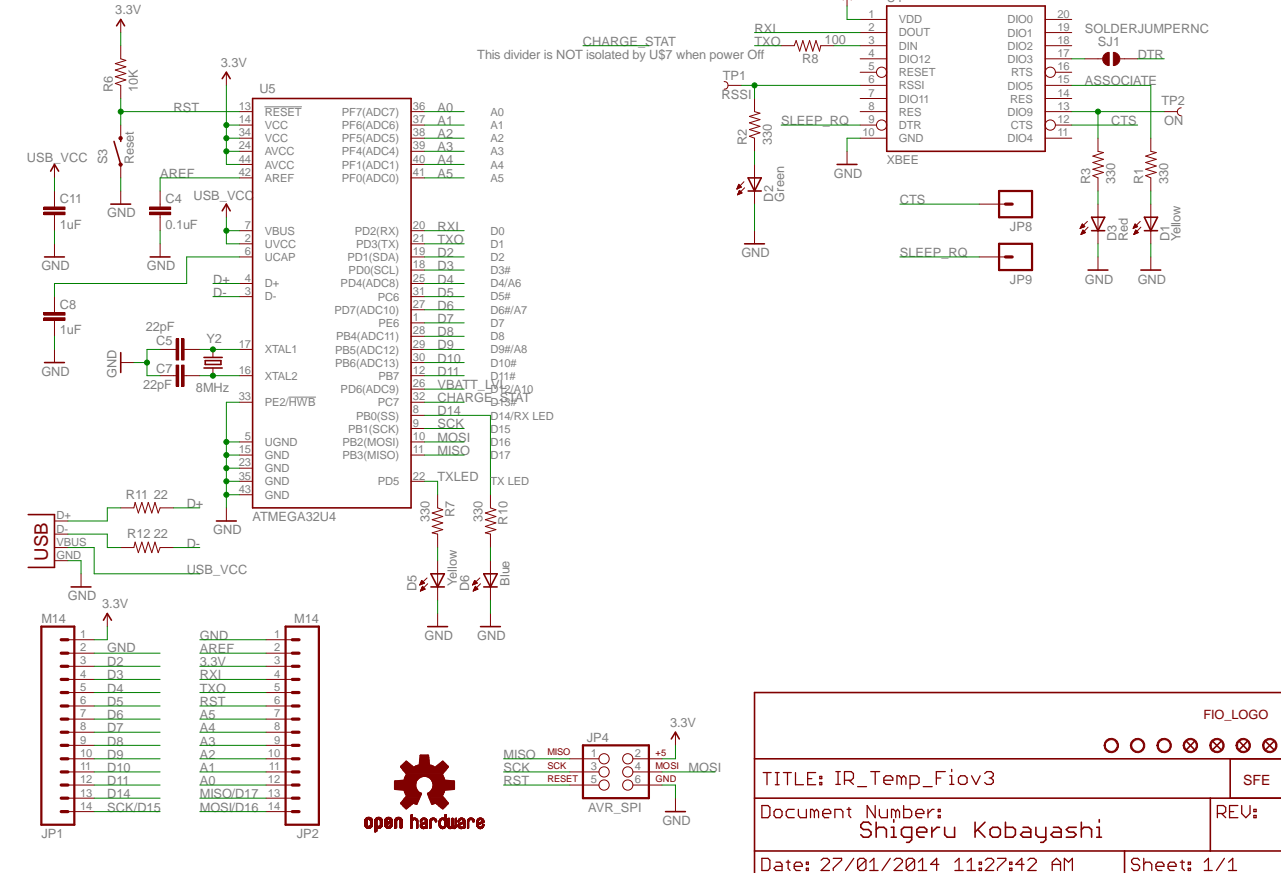

FIO_LOGO		SFE	
TITLE: IR_Temp_Fiov3		REV:	
Document Number: Shigeru Kobayashi		REV:	
Date: 27/01/2014 11:27:42 AM	Sheet: 1/1		

New on v3:  
 Change to ATmega32U4  
 Switch to microUSB  
 Change to 8MHz Xtal  
 Add battery voltage detect  
 Add Charge Status to ATmega  
 Update reset switch  
 Removed FTDI Connection  
 Re-arranged and re-named SPI pins  
 Re-ordered Analog pins  
 Changed PWM pin designator to -  
 Changed VCC to 3.3V

